

**ELECTRIC VERTICAL PUMPS
S Series (Standard Duty)**

SRS Crisafulli™ **Standard Duty** Vertical Pumps are direct driven centrifugal pumps, manufactured in standard 6 foot lengths from base to discharge (optional lengths available), complete with an A36 steel pump volute and impeller, drive shaft, one double roller thrust bearing, three or more ball bearings, bearing protection systems with extended lubrication lines, motor base plate, electric motor, NPT threaded discharge (standard), A36 steel pump mount plate included.

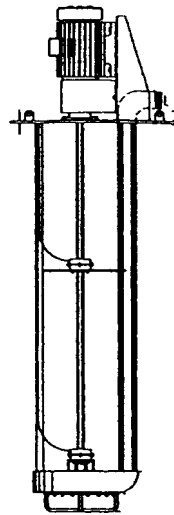

SRS CRISAFULLI, INC.
1610 Crisafulli Drive
P.O. Box 1051
Glendive, MT 59330-1051 USA
Phone: 1-406-365-3393
Toll-free: 1-800-442-7867
Fax: 1-406-365-8088

PUMP SIZE	HP	MODEL NUMBER * see note below	EST. WT. (LBS.)
2"	1	VD022S-001-4	250
2"	2	VD022S-002-4	260
2"	3	VD022S-003-4	280
2"	5	VD022S-005-4	290
2"	5	VD022HPS-005-2	295
2"	7.5	VD022HPS-007-2	340
2"	10	VD022HPS-010-2	350
2.5"	3	VD252S-003-4	300
2.5"	5	VD252S-005-4	310
2.5"	15	VD252HPS-015-2	475
2.5"	20	VD252HPS-020-2	500
2.5"	25	VD252HPS-025-2	625
3"	5	VD032S-005-4	350
3"	7.5	VD032S-007-4	400
3"	10	VD032S-010-4	410
3"	15	VD032S-015-4	515
3"	20	VD032S-020-4	540
4"	5	VD042S-005-4	400
4"	7.5	VD042S-007-6	450
4"	10	VD042S-010-6	460
4"	15	VD042S-015-6	565
4"	20	VD042S-020-4	590
4"	25	VD042S-025-4	715
4"	30	VD042S-030-4	755
4"	40	VD042S-040-4	840
4"	50	VD042S-050-4	900

Pumps above include electric motor.

* **NOTE:** The final digit of the model number denotes the RPM of the electric motor:
-2 denotes 3,450 RPM; -4 denotes 1,750 RPM, -6 denotes 1,150 RPM.

** Please consult the factory for pumps exceeding 20 feet in length.

Options & Accessories	
Custom pump mount plate(s)	Consult Factory
Discharge adapters	Consult Factory
Stainless steel wetted parts	Consult Factory
Electrical Control Panels	See Section 6

SRS CRISAFULLI, INC.
 1610 Crisafulli Drive
 P.O. Box 1051
 Glendive, MT 59330-1051 USA
 Phone: 1-406-365-3393
 Toll-free: 1-800-442-7867
 Fax: 1-406-365-8088

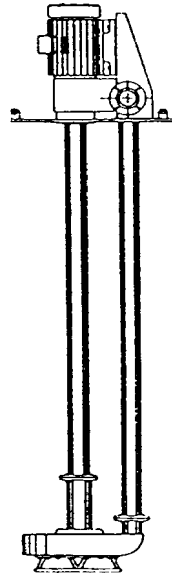

**ELECTRIC VERTICAL PUMPS
 S Series (Severe Duty)**

SRS Crisafulli™ **Severe Duty "S" Series** Vertical Pumps are manufactured with an abrasion resistant, heat treated alloy steel pump volute and impeller (Brinell 400 hardness). The pump drive shaft and bearings are totally enclosed in an oil filled ventilated enclosure with tandem mechanical shaft seals, and flanged discharge. A36 steel pump mount plate included.

PUMP SIZE	HP	MODEL NUMBER * see note below	EST. WT. (LBS.)
2"	1	VD022V001-4	250
2"	2	VD022V-002-4	260
2"	3	VD022V-003-4	280
2"	5	VD022V-005-4	290
2"	5	VD022HPV-005-2	295
2"	7.5	VD022HPV-007-2	340
2"	10	VD022HPV-010-2	350
2.5"	3	VD252V-003-4	300
2.5"	5	VD252V-005-4	310
2.5"	15	VD252HPV-015-2	475
2.5"	20	VD252HPV-020-2	500
2.5"	25	VD252HPV-025-2	625
3"	5	VD032V-005-4	350
3"	7.5	VD032V-007-4	400
3"	10	VD032V-010-4	410
3"	15	VD032V-015-4	515
3"	20	VD032V-020-4	540
4"	5	VD042V-005-6	400
4"	7.5	VD042V-007-6	450
4"	10	VD042V-010-6	460
4"	15	VD042V-015-4	565
4"	20	VD042V-020-4	590
4"	25	VD042V-025-4	715
4"	30	VD042V-030-4	755
4"	40	VD042V-040-4	840
4"	50	VD042V-050-4	900

Pumps above include electric motor.

* **NOTE:** The final digit of the model number denotes the RPM of the electric motor:
 -2 denotes 3,450 RPM; -4 denotes 1,750 RPM, -6 denotes 1,150 RPM.

** **Please consult factory for pumps exceeding 20 feet in length.**

Options & Accessories	
Custom pump mount plate(s)	Consult Factory
Discharge adapters	Consult Factory
Stainless steel wetted parts	Consult Factory
Electrical Control Panels	See Section 6

**ELECTRIC VERTICAL PUMPS
J Series (Severe Duty)**

SRS Crisafulli™ **Severe Duty** Vertical Pumps are manufactured with an abrasion resistant, heat treated alloy steel pump volute & impeller (Brinell 400 hardness). The pump drive shaft and bearings are totally enclosed in an oil filled, ventilated enclosure with tandem mechanical shaft seals, flanged discharge. A36 steel pump mount plate included.

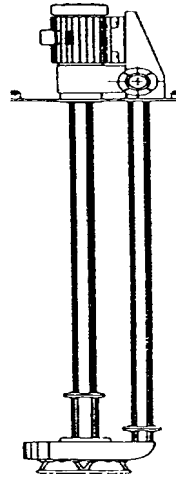

SRS CRISAFULLI, INC.
1610 Crisafulli Drive
P.O. Box 1051
Glendive, MT 59330-1051 USA
Phone: 1-406-365-3393
Toll-free: 1-800-442-7867
Fax: 1-406-365-8088

PUMP SIZE	HP	MODEL NUMBER * see note below	EST. WT.(LBS.)
2"	2	VD029V-002-4	250
2"	3	VD029V-003-4	275
2"	5	VD029V-005-4	285
2"	7.5	VD029V-007-4	330
2"	10	VD029V-010-4	360
2.5"	3	VD259V-003-4	300
2.5"	5	VD259V-005-4	310
2.5"	7.5	VD259V-007-4	360
2.5"	10	VD259V-010-4	370
2.5"	15	VD259V-015-4	425
2.5"	20	VD259V-020-4	450
3"	5	VD039V-005-4	350
3"	7.5	VD039V-007-4	400
3"	10	VD039V-010-4	410
3"	15	VD039V-015-6	630
3"	15	VD039V-015-4	515
3"	20	VD039V-020-4	540
3"	25	VD039V-025-4	665
3"	30	VD039V-030-4	705
4"	5	VD049V-005-4	400
4"	10	VD049V-010-4	460
4"	15	VD049V-015-4	565
4"	20	VD049V-020-6	700
4"	30	VD049V-030-6	895
4"	20	VD049V-020-4	590
4"	30	VD049V-030-4	755
4"	40	VD049V-040-4	835
4"	50	VD049V-050-4	900
4"	75	VD049V-075-4	1,150
4"	100	VD049V-100-4	1,440

(Pumps above include electric motor.)

* **NOTE:** The final digit of the model number denotes the RPM of the electric motor:
-2 denotes 3,450 RPM; -4 denotes 1,750 RPM, -6 denotes 1,150 RPM.

** **Please consult factory for pumps exceeding 20 feet in length.**

Options & Accessories	
Custom pump mount plate(s)	Consult Factory
Discharge adapters	Consult Factory
Stainless steel wetted parts	Consult Factory
Electric Motors	See Section 6
Electrical Control Panels	See Section 6

SM0201/R0701

SRS CRISAFULLI INC.
 1610 Crisafulli Drive
 P.O. Box 1051
 Glendive, MT 59330-1051 USA
 Phone: 1-406-365-3393
 Toll-free: 1-800-442-7867
 Fax: 1-406-365-8088

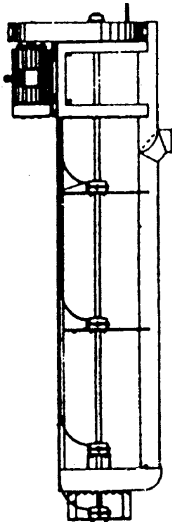

ELECTRIC VERTICAL PUMPS
L Series Belt Drive (Standard Duty)

SRS Crisafulli™ "L" Series Standard Duty Vertical Pumps are belt driven centrifugal pumps. The pumps are manufactured in standard 11 foot lengths from base to discharge (optional lengths available) complete with an A36 steel pump volute and impeller, drive shaft, one double roller thrust bearing, three or more ball bearings, bearing protection systems with extended lubrication lines, belt & sheave speed reduction, belt & sheave guard, adjustable motor base plate, a hose adapter discharge (other discharges available.)

PUMP SIZE	MODEL NUMBER	BRAKE HP RANGE	SHAFT SIZE (INCHES)	EST. WT. (LBS.)
4"	VB04RA-000	3 - 20	1-1/2"	1,100
4"	VB04IA-000	5 - 30	1-1/2"	1,150
4"	VB04HA-000	7.5 - 40	1-1/2"	1,200
6"	VB06RA-000	5 - 30	1-1/2"	1,200
6"	VB06IA-000	10 - 60	1-1/2"	1,275
6"	VB06HA-000	15 - 75	2"	1,400
8"	VB08RA-000	7.5 - 40	1-1/2"	1,300
8"	VB08IA-000	20 - 60	2"	1,450
8"	VB08HA-000	75 - 150	2-7/16"	1,650
10"	VB10RA-000	15 - 40	2"	1,450
10"	VB10IA-000	25 - 60	2"	1,550
10"	VB10HA-000	75 - 150	2-7/16"	1,700
12"	VB12RA-000	15 - 60	2"	1,750
12"	VB12IA-000	25 - 60	2"	1,900
12"	VB12HA-000	75 - 150	2-7/16"	1,950
16"	VB16RA-000	30 - 60	2"	2,350
16"	VB16HA-000	75 - 150	2-7/16"	2,550

All pumps (above) are **less electric motor.**

**** Please consult the factory for vertical belt-driven pumps exceeding 17 feet in length.**

Options & Accessories	
Custom pump mount plate(s)	Consult Factory
Discharge adapters	Consult Factory
Stainless steel wetted parts	Consult Factory
Truck load-out stands	See Page 5-14
Electric Motors	See Section 6
Electrical Control Panels	See Section 6

SRS CRISAFULLI INC.
 1610 Crisafulli Drive
 P.O. Box 1051
 Glendive, MT 59330-1051 USA
 Phone: 1-406-365-3393
 Toll-free: 1-800-442-7867
 Fax: 1-406-365-8088

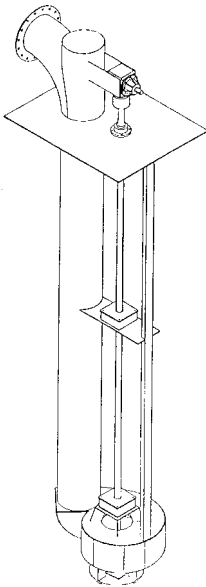

VERTICAL GEARBOX PUMPS
L Series (Standard Duty)

SRS Crisafulli™ "L" Series **Standard Duty** Vertical Gearbox Pumps are centrifugal pumps with a right angle, top mounted gearbox. The vertical pumps are manufactured in standard 11 foot lengths from base to discharge (optional lengths available) complete with an A36 steel pump volute and impeller, drive shaft, one double roller thrust bearing, three or more ball bearing bearing protection systems with extended lubrication lines, right angle gearbox with a ratio of 1 to 1 (other ratios available), P.T.O. shaft, a hose adapter discharge (other discharge styles available), maximum gearbox HP is 150.

PUMP SIZE	MODEL NUMBER	BRAKE HP RANGE	SHAFT SIZE	EST. WT. (LBS.)
4"	VG04RA	3-10	1-1/2"	1,100
4"	VG04IA	5-15	1-1/2"	1,150
4"	VG04HA	10-25	1-1/2"	1,200
6"	VG06RA	10-20	1-1/2"	1,125
6"	VG06IA	15-30	1-1/2"	1,200
6"	VG06HA	20-50	1-1/2"	1,400
8"	VG08RA	10-25	1-1/2"	1,250
8"	VG08IA	20-50	1-1/2"	1,450
8"	VG08HA	30-60	1-1/2"	1,650
10"	VG10RA	10-30	2"	1,500
10"	VG10IA	25-75	2"	1,550
10"	VG10HA	30-100	2"	1,700
12"	VG12RA	10-30	2"	1,750
12"	VG12IA	30-75	2"	1,750
12"	VG12HA	40-125	2"	1,950
16"	VG16RA	30-75	2"	2,350
16"	VG16HA	50-150	2"	2,550

Note: Please contact the Factory for Vertical gearbox pumps for **severe duty** applications.

**** Please consult the factory for vertical gearbox pumps exceeding 20 feet in length.**

Options & Accessories	
Custom pump mount plate(s)	Consult Factory
Discharge adapters	Consult Factory
Stainless steel wetted parts	Consult Factory
Truck load-out stands	See Page 5-14

SRS CRISAFULLI INC.
 1610 Crisafulli Drive
 P.O. Box 1051
 Glendive, MT 59330-1051 USA
 Phone: 1-406-365-3393
 Toll-free: 1-800-442-7867
 Fax: 1-406-365-8088

**VERTICAL DUAL DRIVE
 PTO / ELECTRIC PUMPS
 L Series (Standard Duty)**

SRS Crisafulli™ "L" Series Standard Duty **Dual Drive Pumps** are belt-driven centrifugal pumps which incorporate a right angle gearbox allowing the pump to also be PTO driven. The dual drive vertical pumps are manufactured in standard 11 foot lengths from base to discharge (optional lengths available) complete with an A36 steel pump volute and impeller, drive shaft, one double roller thrust bearing, three or more ball bearings, bearing protection systems with extended lubrication lines, belt & sheave speed reduction, belt & sheave guard, adjustable motor base plate, PTO shaft, **right angle gearbox** with a **1 to 1** ratio (other ratios available), a **hose adaptor discharge** (other discharge styles available). **Maximum gearbox hp is 100.**

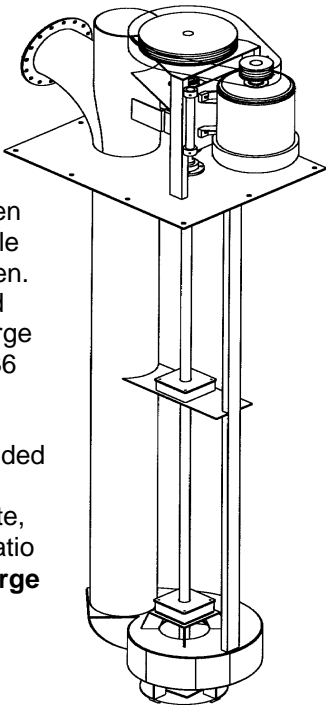

PUMP SIZE	MODEL NUMBER	HP	SHAFT SIZE	ESTIMATED WT. * SEE BELOW
8"	VGD08HA-060	60	2"	Please consult factory
10"	VGD10RA-030	30	2"	Please consult factory
10"	VGD10IA-060	60	2"	Please consult factory
10"	VGD10HA-100	100	2-7/16"	Please consult factory
12"	VGD12RA-030	30	2"	Please consult factory
12"	VGD12IA-075	75	2-7/16"	Please consult factory
12"	VGD12HA-100	100	2-7/16"	Please consult factory
16"	VGD16RA-075	75	2-7/16"	Please consult factory
16"	VGD16RA-100	100	2-7/16"	Please consult factory

Pumps above include electric motor.

* We recommend that you contact the factory for an estimated weight on dual drive pumps, as unit weight is substantially affected by variations in baseplate size, finished pump length, pump size and motor.

** **Please consult the Factory for vertical dual drive pumps exceeding 20 feet in length.**

Note: Please contact the Factory for Dual Drive pumps for **severe duty** applications.

Options & Accessories	
Custom pump mount plate(s)	Consult Factory
Discharge adapters	Consult Factory
Stainless steel wetted parts	Consult Factory
Truck load-out stands	See Page 5-14